

# DİŞ AÇMA UÇLARI VE TAKIMLARI

THREADING INSERTS AND TOOLS  
GEWINDESCHNEIDPLATTEN UND WERKZEUGE

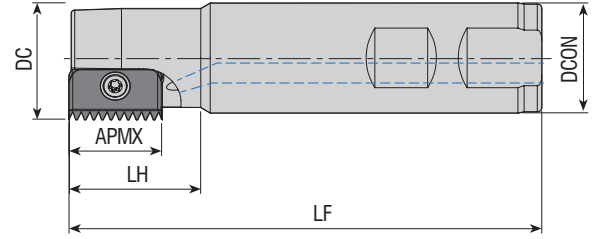



Takım Kodu Ordering Code Bestell-Bezeichnung	Stok Stock Lager	Takım Ölçüleri (mm) Dimension (mm) Abmessung (mm)						Kesici Uç Insert Wendeschneidplatte	Yedek Parçaları / Spare Parts / Ersatzteile	
		DC	ZEFP	DCON	LF	LH	APMX		Sıkma Vidası Screw Schraube	Tork Anahtar Torx Key Torx-Schlüssel
VTM-C14-D14-W20-L100-Z01-H	●	14	1	20	100	25	14		3008-M2.5x6	82-T08
VTM-C21-D18-W20-L100-Z01-H	●	18	1	20	100	30	21		4015-M4x9	
VTM-C21-D21-W25-L125-Z01-H	●	21	1	25	125	40	21			4015-M4x11
VTM-C21-D25-W20-L125-Z01-H	●	25	1	20	125	30	21			
VTM-C21-D28-W25-L90-Z01-H	●	28	1	25	90	30	21			
VTM-C21-D38-W32-L90-Z03-H	●	38	3	32	90	30	21			
VTM-C21-D38-W32-L120-Z03-H	●	38	3	32	120	30	21			
VTM-C21-D43-W32-L90-Z03-H	●	43	3	32	90	30	21		1020-M5x14	80-T20
VTM-C30-D29-W25-L150-Z01-H	●	29	1	25	150	50	30			

CPT Ucuna Uygun. / Compatible with CPT Insert. / Kompatibel mit CPT Wendeplatten.

Sipariş Örneği/Ordering Example/Bestellbeispiel  
 1 ad./pcs./stück VTM-C14-D14-W20-L100-Z01-H

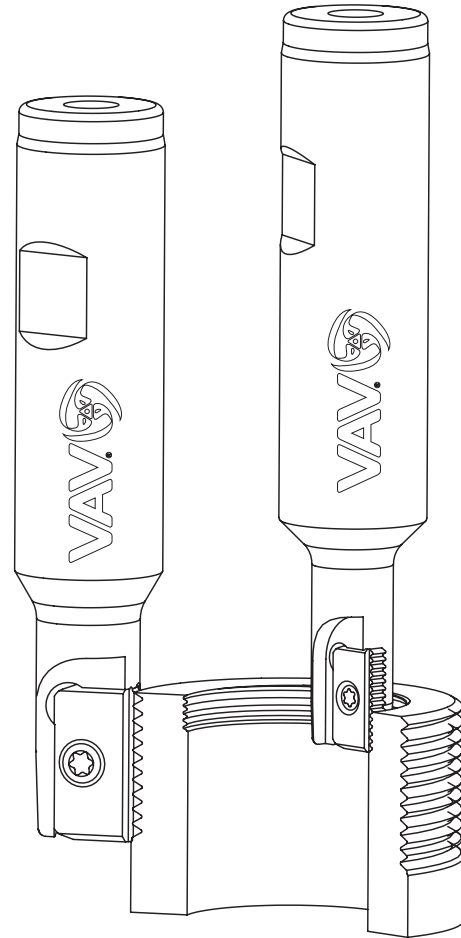
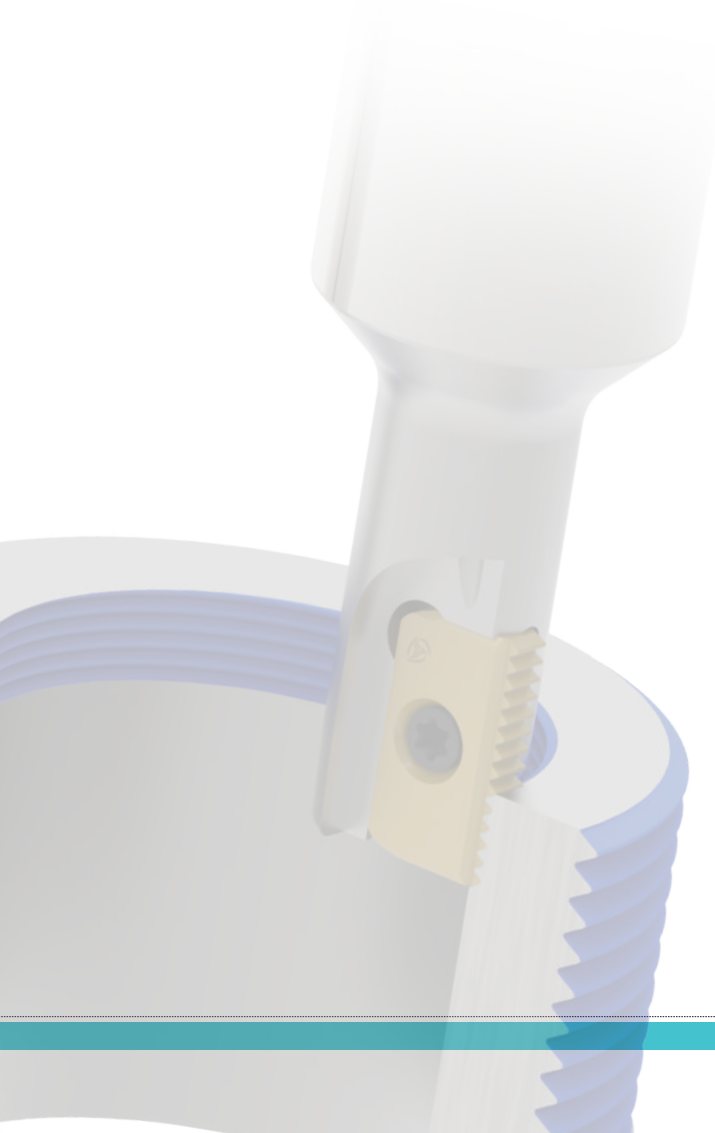

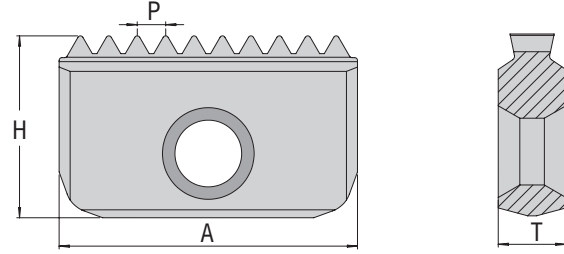
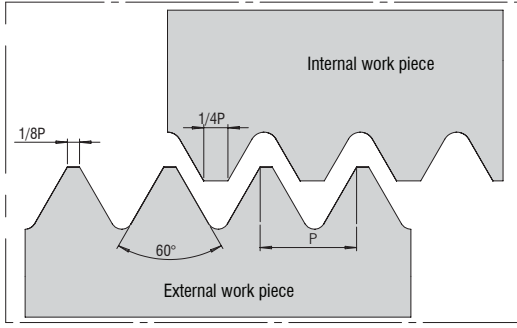

Ürün Kodu Product Code Artikelnummer	Insert Tipi Insert Type Wendeplatten Typ A	Takım Ölçüleri (mm) Dimension (mm) Abmessung (mm)		
		Adım Pitch Wendeplatten Typ	H	T
VDTI14.050.M	C14	0.5	7.5	3.1
VDTI14.075.M		0.75	7.5	3.1
VDTE14.075.M		0.75	7.5	3.1
VDTI14.100.M		1.00	7.5	3.1
VDTE14.100.M		1.00	7.5	3.1
VDTI14.125.M		1.25	7.5	3.1
VDTE14.125.M		1.25	7.5	3.1
VDTI14.150.M		1.50	7.5	3.1
VDTE14.150.M		1.50	7.5	3.1
VDTI14.175.M		1.75	7.5	3.1
VDTE14.175.M		1.75	7.5	3.1
VDTI14.200.M		2.00	7.5	3.1
VDTE14.200.M		2.00	7.5	3.1
VDTI14.250.M		2.50	7.5	3.1
VDTE14.250.M		2.50	7.5	3.1

Ürün Kodu Product Code Artikelnummer	Insert Tipi Insert Type Wendeplatten Typ A	Takım Ölçüleri (mm) Dimension (mm) Abmessung (mm)		
		Adım Pitch Wendeplatten Typ (P)	H	T
VDTI21.100.M	C21	1.00	12	4.7
VDTE21.100.M		1.00	12	4.7
VDTI21.150.M		1.50	12	4.7
VDTE21.150.M		1.50	12	4.7
VDTI21.175.M		1.75	12	4.7
VDTI21.200.M		2.00	12	4.7
VDTE21.200.M		2.00	12	4.7
VDTI21.250.M		2.50	12	4.7
VDTE21.250.M		2.50	12	4.7
VDTI21.300.M		3.00	12	4.7
VDTE21.300.M		3.00	12	4.7
VDTI21.350.M		3.5	12	4.7

Sipariş Örneği/Ordering Example/Bestellbeispiel  
 1 ad./pcs./stück VDTI14.050.M

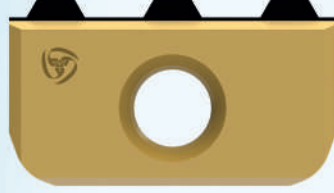
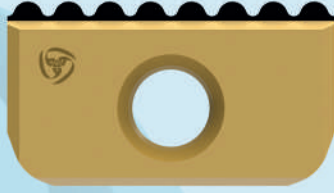

# SPECIAL THREADING MILLING TOOLS

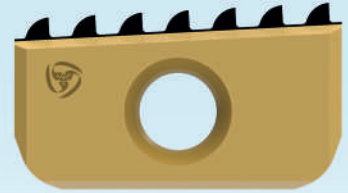
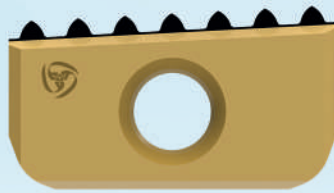
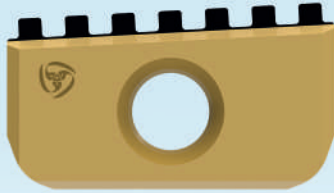

## DİŞ TARAĞI BİLGİ ALMA FORMU

INFORMATION FORM FOR SPECIAL THREAD MILLING INSERTS  
INFORMATIONFORM FÜR SONDER GEWINDEFÄSERWERKZEUGE

Insert Type	Thread Type	Thread Pitch mm	Thread Profile
C 14	External <input type="checkbox"/> Internal <input type="checkbox"/> Nötr <input type="checkbox"/>		ISO <input type="checkbox"/> UN <input type="checkbox"/> WHIT <input type="checkbox"/> NPT <input type="checkbox"/> NPTF <input type="checkbox"/> BSPT <input type="checkbox"/> NPS <input type="checkbox"/> NPSF <input type="checkbox"/> PG <input type="checkbox"/>
C 21	External <input type="checkbox"/> Internal <input type="checkbox"/> Nötr <input type="checkbox"/>		ISO <input type="checkbox"/> UN <input type="checkbox"/> WHIT <input type="checkbox"/> NPT <input type="checkbox"/> NPTF <input type="checkbox"/> BSPT <input type="checkbox"/> NPS <input type="checkbox"/> NPSF <input type="checkbox"/> PG <input type="checkbox"/>



**ROUND**  
Dış çap / External / Außen

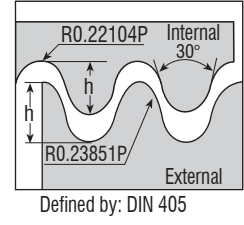
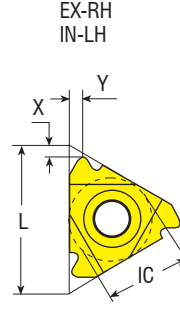

Defined by: DIN 405

Uç Kodu Insert Code Wendeplatten-Bezeichnung	Stok Stock Lager		Uç Ölçüleri (mm) Insert Dimension (mm) Abmessung (mm)						UYUMLU TAKIM / COMPATIBLE TOOLHOLDER / KOMPATIBLES WERKZEUG	
	R	L	IC	L	Adım / Pitch / Wendeplatten Typ	(TPI)	h	X		Y
16ST ER/L 10RD	○	○	9.53	16	10		1.27	1.1	1.2	SER/L .....16C
16ST ER/L 8RD	○	○	9.53	16	8		1.59	1.4	1.3	
16ST ER/L 6RD	○	○	9.53	16	6		2.12	1.5	1.7	
22ST ER/L 6RD	○	○	13	22	6		2.12	1.5	1.7	SER/L .....22C
22ST ER/L 4RD	○	○	13	22	4		3.18	2.2	2.3	
27ST ER/L 4RD	○	○	15.88	27	4		3.18	2.2	2.3	



**ROUND**  
İç çap / Internal / Innen

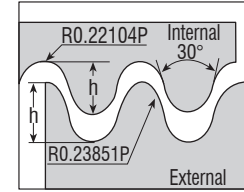
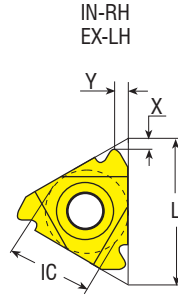

Defined by: DIN 405

Uç Kodu Insert Code Wendeplatten-Bezeichnung	Stok Stock Lager		Uç Ölçüleri (mm) Insert Dimension (mm) Abmessung (mm)						UYUMLU TAKIM / COMPATIBLE TOOLHOLDER / KOMPATIBLES WERKZEUG	
	R	L	IC	L	Adım / Pitch / Wendeplatten Typ	(TPI)	h	X		Y
16ST IR/L 10RD	○	○	9.53	16	10		1.27	1.1	1.2	SIR/L ..... 16C
16ST IR/L 8RD	○	○	9.53	16	8		1.59	1.4	1.3	
16ST IR/L 6RD	○	○	9.53	16	6		2.12	1.5	1.7	
22ST IR/L 6RD	○	○	13	22	6		2.12	1.5	1.7	SIR/L S... 22C
22ST IR/L 4RD	○	○	13	22	4		3.18	2.2	2.3	
27ST IR/L 4RD	○	○	15.88	27	4		3.18	2.2	2.3	

R: Sağ / Right / Rechts L: Sol / Left / Links  
● Stokta / In Stock / Auf Lager ○ Stokta Yok / Non Stock Item / Kein Lagerartikel, Lieferzeit auf Anfrage

Sipariş Örneği/Ordering Example/Bestellbeispiel  
1 ad./pcs./stück 16ST ER 10RD

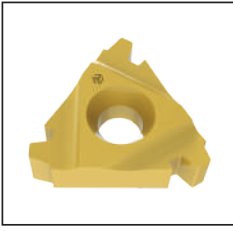

## TRAPEZ

Diş çap / External / Außen

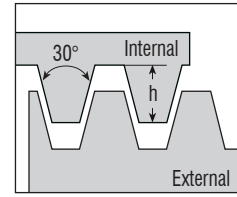
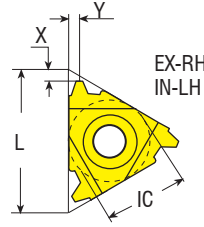

Defined by: DIN 103

**Uç Kodu**  
**Insert Code**  
Wendeplatten-Bezeichnung

Stok  
Stock  
Lager

Uç Ölçüleri (mm)  
Insert Dimension (mm)  
Abmessung (mm)

Uç Kodu Insert Code Wendeplatten-Bezeichnung	Stok Stock Lager		Uç Ölçüleri (mm) Insert Dimension (mm) Abmessung (mm)					UYUMLU TAKIM / COMPATIBLE TOOLHOLDER / KOMPATIBLES WERKZEUG	
	R	L	IC	L	Adım / Pitch / Wendeplatten Typ	h	X		Y
16ST ER/L 1.5TR	○	○	9.53	16	1.5	0.90	1.0	1.1	SER/L 2525 M16C-T
16ST ER/L 2.0TR	○	○	9.53	16	2.0	1.25	1.1	1.3	
16ST ER/L 2.5TR	○	○	9.53	16	2.5	1.55	1.2	1.4	
16ST ER/L 3.0TR	○	○	9.53	16	3.0	1.75	1.3	1.5	
22ST ER/L 4.0TR	○	○	13	22	4.0	2.25	1.7	1.9	SER/L 2525 M22C-T
22ST ER/L 5.0TR	○	○	13	22	5.0	2.75	2.1	2.5	
22ST ER/L 6.0TR	○	○	13	22	6.0	3.50	2.3	2.7	
27ST ER/L 6.0TR	○	○	15.88	27	6.0	3.50	2.3	2.7	TER/L ....27

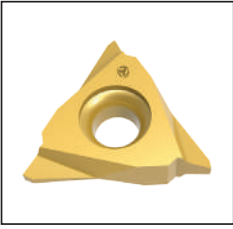

## TRAPEZ

Diş çap / External / Außen  
V Tip / V Type / V Typ

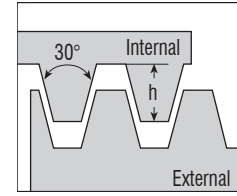
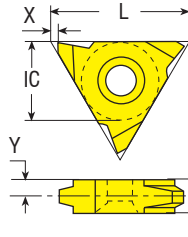

Defined by: DIN 103

**Uç Kodu**  
**Insert Code**  
Wendeplatten-Bezeichnung

Stok  
Stock  
Lager

Uç Ölçüleri (mm)  
Insert Dimension (mm)  
Abmessung (mm)

Uç Kodu Insert Code Wendeplatten-Bezeichnung	Stok Stock Lager		Uç Ölçüleri (mm) Insert Dimension (mm) Abmessung (mm)						
	R	L	IC	L	Adım / Pitch / Wendeplatten Typ	h	X	Y	S
27VT ER/L 6.0TR	○	○	15.88	27	6.0	3.50	1.0	3.3	6.38
27VT ER/L 7.0TR	○	○	15.88	27	7.0	4.00	1.0	3.3	6.38
27VT ER/L 8.0TR	○	○	15.88	27	8.0	4.50	1.0	3.3	6.38

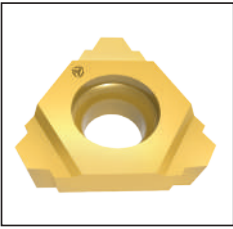

## TRAPEZ

Diş çap / External / Außen  
U Tip / U Type / U Typ

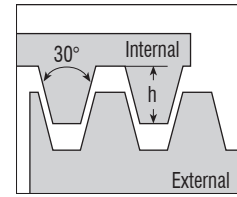
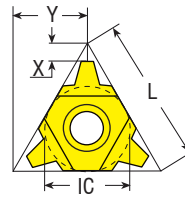

Defined by: DIN 103

**Uç Kodu**  
**Insert Code**  
Wendeplatten-Bezeichnung

Stok  
Stock  
Lager

Uç Ölçüleri (mm)  
Insert Dimension (mm)  
Abmessung (mm)

Uç Kodu Insert Code Wendeplatten-Bezeichnung	Stok Stock Lager		Uç Ölçüleri (mm) Insert Dimension (mm) Abmessung (mm)					
	R	L	IC	L	Adım / Pitch / Wendeplatten Typ	h	X	Y
22UT E 6.0TR	○	○	13	22	6.0	3.50	2.0	11.0
22UT E 7.0TR	○	○	13	22	7.0	4.0	2.3	11.0
22UT E 8.0TR	○	○	13	22	8.0	4.50	2.6	11.0
27UT E 8.0TR	○	○	15.88	27	8.0	4.50	2.6	13.7
27UT E 9.0TR	○	○	15.88	27	9.0	5.00	3.0	13.7

Sipariş Örneği/Ordering Example/Bestellbeispiel

1 ad./pcs./stück 16ST ER 1.5TR 90 / 91

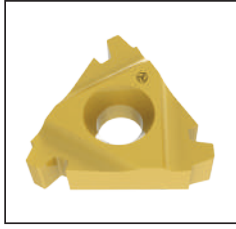

**TRAPEZ**  
İç çap / Internal / Innen

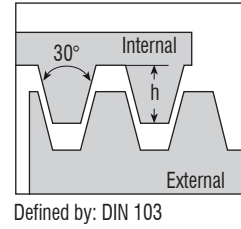
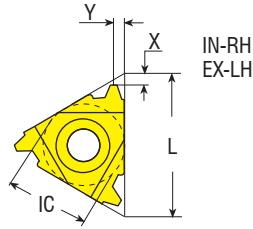

**Uç Kodu**  
**Insert Code**  
Wendeplatten-Bezeichnung

Stok  
Stock  
Lager

Uç Ölçüleri (mm)  
Insert Dimension (mm)  
Abmessung (mm)

Uç Kodu Insert Code Wendeplatten-Bezeichnung	Stok Stock Lager		IC	L	Adım / Pitch / Wendeplatten Typ	h	X	Y	UYUMLU TAKIM / COMPATIBLE TOOLHOLDER / KOMPATIBLES WERKZEUG
	R	L							
16ST IR/L 1.5TR	○	○	9.53	16	1.5	0.90	1.0	1.1	SIR/L S25R 16C-T
16ST IR/L 2.0TR	○	○	9.53	16	2.0	1.25	1.1	1.3	
16ST IR/L 2.5TR	○	○	9.53	16	2.5	1.53	1.2	1.4	
16ST IR/L 3.0TR	○	○	9.53	16	3.0	1.75	1.3	1.5	
22ST IR/L 4.0TR	○	○	13	22	4.0	2.25	1.7	1.9	SIR/L S25R 22C-T
22ST IR/L 5.0TR	○	○	13	22	5.0	2.75	2.1	2.5	
22ST IR/L 6.0TR	○	○	13	22	6.0	3.50	2.3	2.7	
27ST IR/L 6.0TR	○	○	15.88	27	6.0	3.50	2.3	2.7	TIR/L S... 27

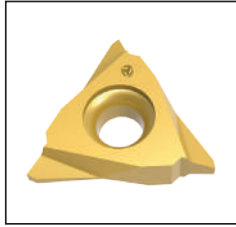

**TRAPEZ**  
İç çap / Internal / Innen  
V Tip / V Type / V Typ

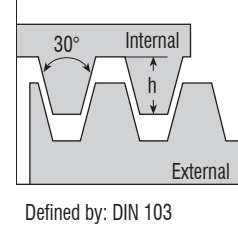
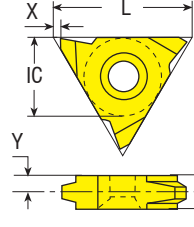

**Uç Kodu**  
**Insert Code**  
Wendeplatten-Bezeichnung

Stok  
Stock  
Lager

Uç Ölçüleri (mm)  
Insert Dimension (mm)  
Abmessung (mm)

Uç Kodu Insert Code Wendeplatten-Bezeichnung	Stok Stock Lager		IC	L	Adım / Pitch / Wendeplatten Typ	h	X	Y	S
	R	L							
27VT IR/L 6.0TR	○	○	15.88	27	6.0	3.50	1.0	3.3	6.38
27VT IR/L 7.0TR	○	○	15.88	27	7.0	4.00	1.0	3.3	6.38
27VT IR/L 8.0TR	○	○	15.88	27	8.0	4.50	1.0	3.3	6.38

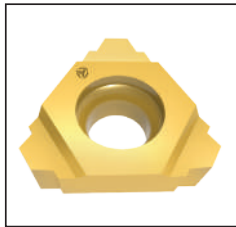

**TRAPEZ**  
İç çap / Internal / Innen  
U Tip / U Type / U Typ

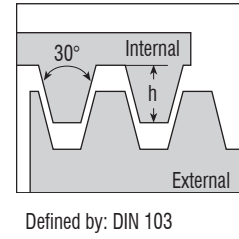
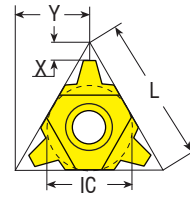

**Uç Kodu**  
**Insert Code**  
Wendeplatten-Bezeichnung

Stok  
Stock  
Lager

Uç Ölçüleri (mm)  
Insert Dimension (mm)  
Abmessung (mm)

Uç Kodu Insert Code Wendeplatten-Bezeichnung	Stok Stock Lager		IC	L	Adım / Pitch / Wendeplatten Typ	h	X	Y
	R	L						
22UT I 6.0TR	○	○	13	22	6.0	3.50	2.0	11.0
22UT I 7.0TR	○	○	13	22	7.0	4.0	2.3	11.0
22UT I 8.0TR	○	○	13	22	8.0	4.50	2.6	11.0
27UT I 8.0TR	○	○	15.88	27	8.0	4.50	2.6	13.7
27UT I 9.0TR	○	○	15.88	27	9.0	5.00	3.0	13.7

R: Sağ / Right / Rechts L: Sol / Left / Links

● Stokta / In Stock / Auf Lager ○ Stokta Yok / Non Stock Item / Kein Lagerartikel, Lieferzeit auf Anfrage

Sipariş Örneği/Ordering Example/Bestellbeispiel

1 ad./pcs./stück 216ST IR 1.5TR

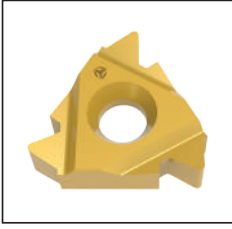

### OIL AND GAS INDUSTRY

Diş çap / External / Außen

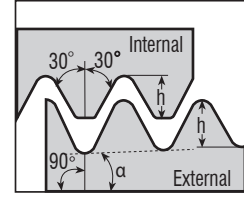
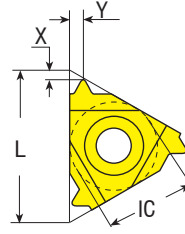

Defined by: API SPEC. 7:1990

#### Uç Kodu Insert Code

Wendeplatten-Bezeichnung

Stok  
Stock  
Lager

Uç Ölçüleri (mm)  
Insert Dimension (mm)  
Abmessung (mm)

R	L	Diş / Thread / Gewinde	IC	Adım / Pitch / (TPI) Wendeplatten Typ	Koniklik / Taper / Konisch	hmin	X	Y	Bağlantı numarası veya boyutu / Connection no. or size
○	○	V-0.038R	22	4	2	3.09	2.1	2.8	NC23-NC50
○	○	V-0.038R	22	4	3	3.08	2.1	2.8	NC56-NC77
○	○	V-0.050	22	4	2	3.75	2.0	2.9	6 5/8" REG, 5 1/2"FH, 6 5/8" FH
○	○	V-0.050	22	4	3	3.74	2.0	2.9	5 1/2", 7 5/8", 8 5/8" REG
○	○	V-0.040	22	5	3	2.99	1.8	2.6	2 3/8"-4 1/2" REG
○	○	V-0.055	22	6	1.5	1.41	2.6	2.0	NC10-NC16
○	○	V-0.038R	27	4	2	3.09	2.1	2.8	NC23-NC50
○	○	V-0.038R	27	4	3	3.08	2.1	2.8	NC56-NC77
○	○	V-0.050	27	4	2	3.75	2.1	3.1	6 5/8" REG, 5 1/2"FH, 6 5/8" FH
○	○	V-0.050	27	4	3	3.74	2.1	3.1	5 1/2", 7 5/8", 8 5/8" REG
○	○	V-0.040	27	5	3	2.99	1.9	2.7	2 3/8"-4 1/2" REG
○	○	V-0.065	27	4	2	2.81	2.3	2.8	2 3/8"IF- 5 1/2IF

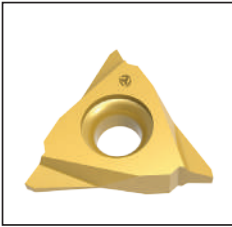

### OIL AND GAS INDUSTRY

Diş çap / External / Außen  
V Tip / V Type / V Typ

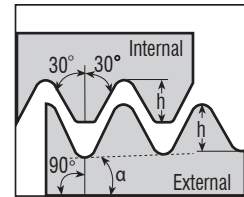
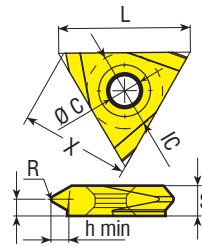

Defined by: API SPEC. 7:1990

#### Uç Kodu Insert Code

Wendeplatten-Bezeichnung

Stok  
Stock  
Lager

Uç Ölçüleri (mm)  
Insert Dimension (mm)  
Abmessung (mm)

R	L	Diş / Thread / Gewinde	IC	Adım / Pitch / (TPI) Wendeplatten Typ	Koniklik / Taper / Konisch	R	hmin	S	C	X	Y	Bağlantı numarası veya boyutu / Connection no. or size
○	○	V-0.040	27	5	3	0.51	3.00	6.38	6.20	23.4	3.9	2 3/8"-4 1/2" REG

R: Sağ / Right / Rechts L: Sol / Left / Links

● Stokta / In Stock / Auf Lager ○ Stokta Yok / Non Stock Item / Kein Lagerartikel, Lieferzeit auf Anfrage

Sipariş Örneği/Ordering Example/Bestellbeispiel

1 ad./pcs./stück 22ST ER 4APIV382



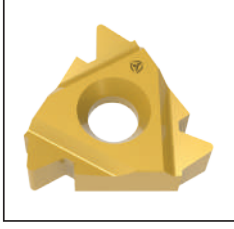

**OIL AND GAS INDUSTRY**  
İç çap / Internal / Innen

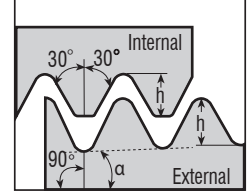
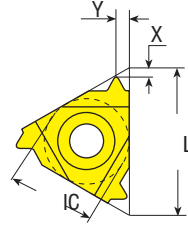

Defined by: API SPEC. 7:1990

**Uç Kodu**  
**Insert Code**

Wendeplatten-Bezeichnung

Stok  
Stock  
Lager

Uç Ölçüleri (mm)  
Insert Dimension (mm)  
Abmessung (mm)

R	L	Diş / Thread / Gewinde	İC	Adım / Pitch / (TPI) Wendeplatten Typ	Koniklik / Taper / Konisch	hmin	X	Y	Bağlantı numarası veya boyutu / Connection no. or size
○	○	V-0.038R	22	4	2	3.09	2.1	2.8	NC23-NC50
○	○	V-0.038R	22	4	3	3.08	2.1	2.8	NC56-NC77
○	○	V-0.050	22	4	2	3.75	2.1	3.1	6 5/8" REG, 5 1/2"FH, 6 5/8" FH
○	○	V-0.050	22	4	3	3.74	2.0	2.9	5 1/2", 7 5/8", 8 5/8" REG
○	○	V-0.040	22	5	3	2.99	1.8	2.6	2 3/8"-4 1/2" REG
○	○	V-0.055	22	6	1.5	1.41	2.6	2.0	NC10-NC16
○	○	V-0.038R	27	4	2	3.09	2.1	2.8	NC23-NC50
○	○	V-0.038R	27	4	3	3.08	2.1	2.8	NC56-NC77
○	○	V-0.050	27	4	2	3.75	2.1	3.1	6 5/8" REG, 5 1/2"FH, 6 5/8" FH
○	○	V-0.050	27	4	3	3.74	2.1	3.1	5 1/2", 7 5/8", 8 5/8" REG
○	○	V-0.040	27	5	3	2.99	1.9	2.7	2 3/8"-4 1/2" REG
○	○	V-0.065	27	4	2	2.81	2.3	2.8	2 3/8"IF- 5 1/2IF



**OIL AND GAS INDUSTRY**  
İç çap / Internal / Innen  
V Tip / V Type / V Typ

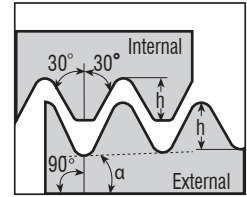
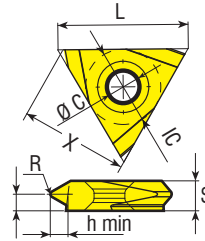

Defined by: API SPEC. 7:1990

**Uç Kodu**  
**Insert Code**

Wendeplatten-Bezeichnung

Stok  
Stock  
Lager

Uç Ölçüleri (mm)  
Insert Dimension (mm)  
Abmessung (mm)

R	L	Diş / Thread / Gewinde	İC	Adım / Pitch / (TPI) Wendeplatten Typ	Koniklik / Taper / Konisch	R	hmin	S	C	X	Y	Bağlantı numarası veya boyutu / Connection no. or size
○	○	V-0.040	27	5	3	0.51	3.00	6.38	6.20	23.4	3.9	2 3/8"-4 1/2" REG

R: Sağ / Right / Rechts L: Sol / Left / Links

● Stokta / In Stock / Auf Lager ○ Stokta Yok / Non Stock Item / Kein Lagerartikel, Lieferzeit auf Anfrage

Sipariş Örneği/Ordering Example/Bestellbeispiel

1 ad./pcs./stück 27VT IR 5API403

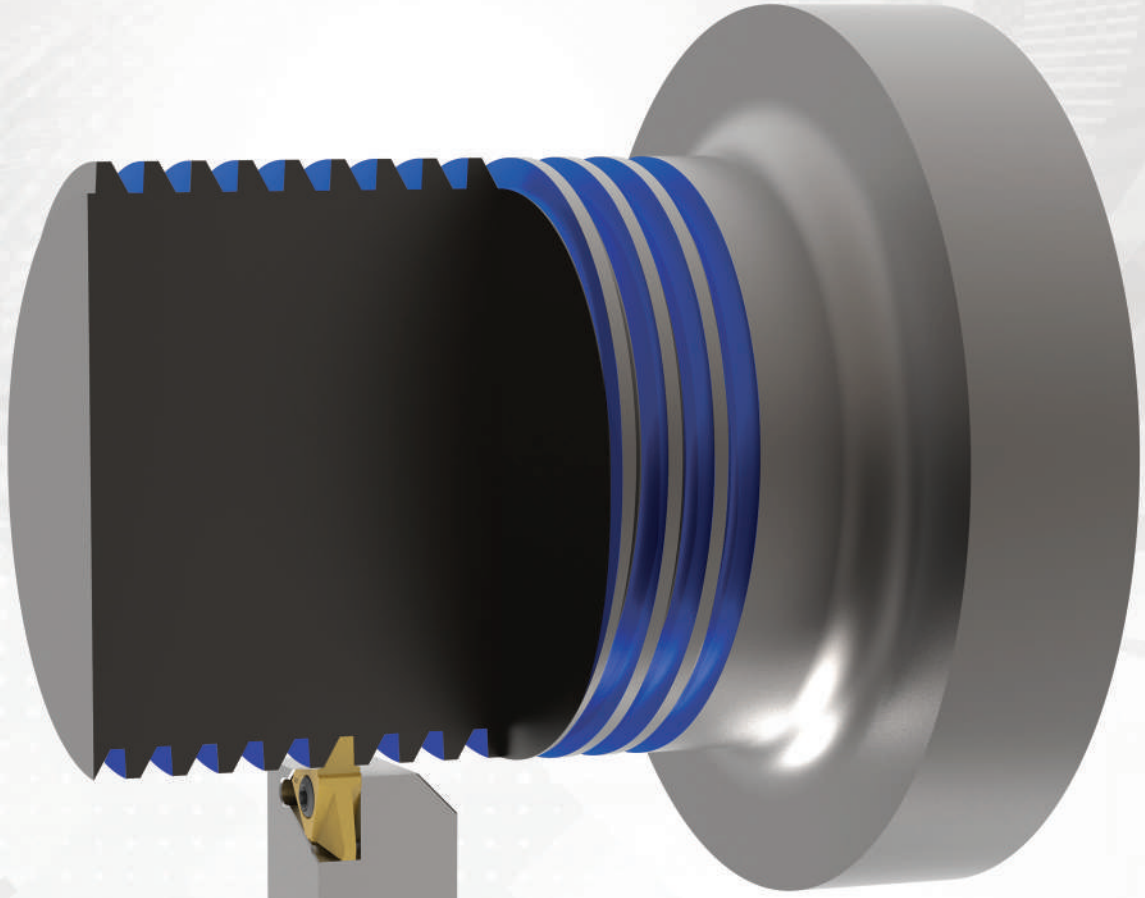

- **DİŞ AÇMA  
ÖZEL ÇÖZÜMLER**
- **THREAD MILLING  
SPECIAL SOLUTIONS**
- **GEWINDE LÖSUNGEN**

[www.vavkesici.com.tr](http://www.vavkesici.com.tr)



VAV

**DIŞ AÇMA ÇÖZÜMLERİ**  
**THREADING SOLUTIONS**  
**GEWINDE LÖSUNGEN**



# DİŞ AÇMA ÇÖZÜMLERİ

## THREADING SOLUTIONS

### GEWINDE LÖSUNGEN



MINI DİŞ FREZELEME  
SOLID THREAD MILLING  
SOLIDE GEWINDEFRASEN



MINI CUT ÖZEL DİŞ AÇMA  
MINI CUT SPECIAL THREADING  
SPEZIELLES GEWINDESCHNEIDEN MINI CUT

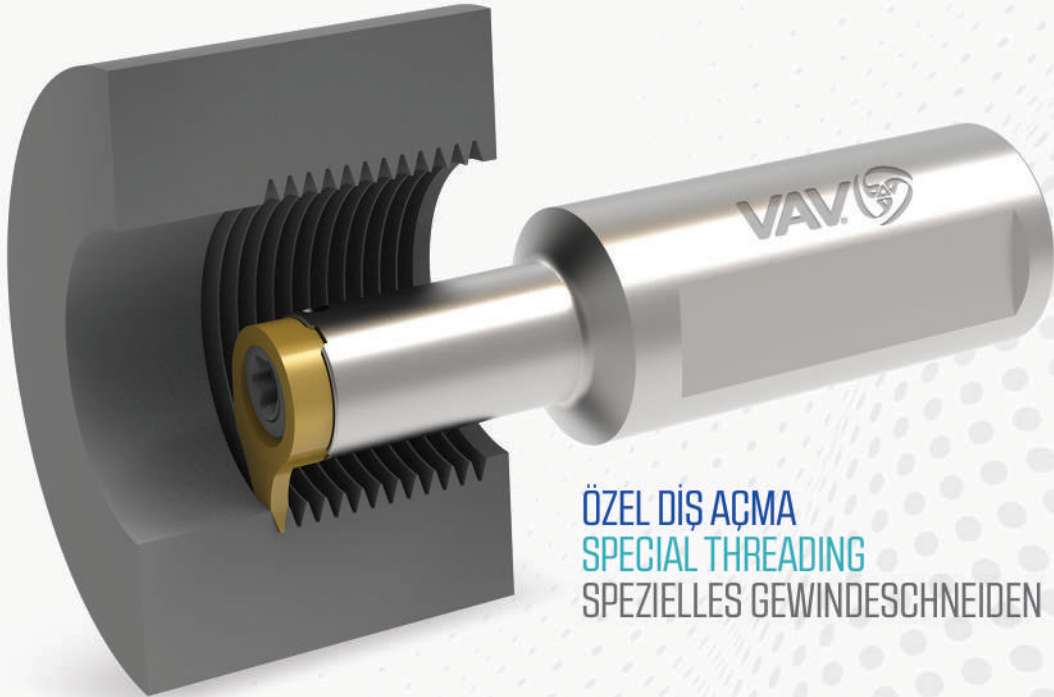

ÖZEL DİŞ AÇMA  
SPECIAL THREADING  
SPEZIELLES GEWINDESCHNEIDEN